

SUMITUBE™ W

[Dual wall heat-shrinkable tubing with meltable liner]

Catalog No. 803 ✓ RoHS directive 10 substances

Waterproofing Flame-retarded UL recognized CSA recognized

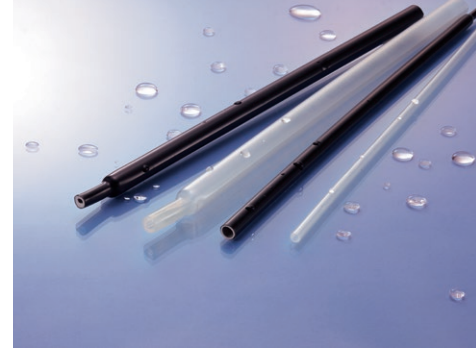

Basic Properties

- Material : Outer : Irradiated cross-linked flexible polyolefin
: Inner : Meltable polyolefin
- Shrink temperature : min. 115°C
- Shrink ratio : Radial change: min. 60%
: Longitudinal change: min. -15%
- Continuous operating temperature : -55 to 105°C

Features

- Dual wall structure using two concentric tubings
- Effective filling for large gaps and voids

Specifications/Approvals

SFP standard (RE4-1080)

Applications

- Insulation, protection and reinforcement for termination and joints of electric wire
- Corrosion protection of pipes or bimetallic joints

Colors

- Black (Inner: Gray), Clear (Inner: Clear)

d: Supplied inside diameter t: Supplied wall thickness
 d': Recovered inside diameter t': Recovered wall thickness

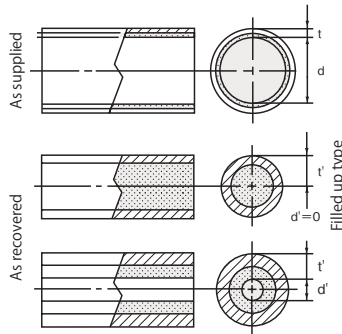

Shrink Properties

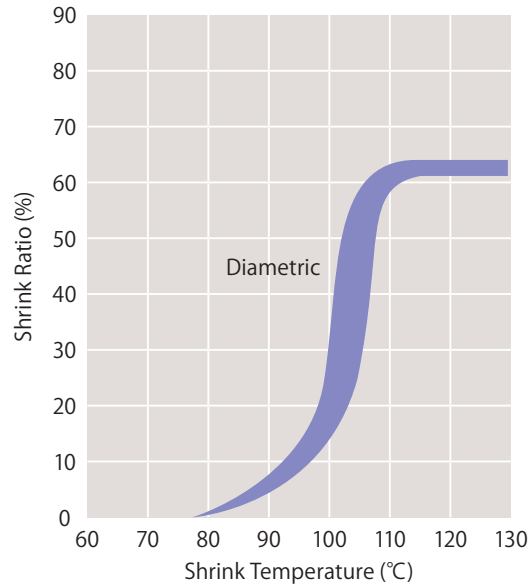

Properties

Properties	Items	Requirements	Typical values*1
Mechanical	Tensile strength	min. 10.4MPa	13.8MPa
	Elongation	min. 200%	475%
	Specific gravity	—	0.94
	Hardness (Shore D)	—	42
Electrical	Dielectric withstand	AC2.5kV x 60 sec., no breakdown	Pass
	Volume resistivity	min. $1.0 \times 10^{14} \Omega \cdot \text{cm}$	$1.7 \times 10^{16} \Omega \cdot \text{cm}$
Chemical	Water absorption	23°C x 24 hours, max. 0.30%	0.06%
	Flammability	Flammable	—

*1: For reference use only; data are for outer tubing

Sizes

Trade size (mm)	As supplied (mm)		After recovered (mm)		Unit length (min.) (m)
	Inside diameter (d)	Wall thickness (nom.) (t)	Inside diameter (max.) (d')	Wall thickness (nom.) (t')	
1.5	1.70 ± 0.20	0.50	Filled up	1.10	0.3
2.5	2.70 ± 0.20	0.50	Filled up	1.40	0.3
3.5	3.50 ± 0.30	0.55	Filled up	1.60	0.3
4.5	4.60 ± 0.30	0.60	Filled up	2.00	0.3
5.5	5.50 ± 0.40	0.65	Filled up	2.20	0.3
7	7.3 ± 0.5	0.65	2.80	1.50	0.3
8	8.2 ± 0.5	0.75	2.80	1.80	0.3
9	9.0 ± 0.5	0.75	2.80	1.90	0.3
10	10.0 ± 0.5	0.75	3.50	1.90	0.3
11	11.0 ± 0.5	0.80	4.00	2.00	0.3
14	14.0 ± 0.6	0.80	5.50	2.10	0.3

SUMITUBE™

A
C
A4
LA
C (UL)
D
A2

B
LB

F (Z)
F3 (Z)
NHR2
NHR4
V (300V)
V (600V)

F2 (Z)
F4 (Z)
B2
B2 (3X)
B8

K
K2

KH200 (TW)

KH230 (TW)

B6
R
AN25

SUMITUBE W

O2C
W3C

O2B2
W3F2
W3B2
W3B2 (4X)
SA2
SA3

IRRAX™TUBE IRRAX™TAPE

A
B
F2
F2 (UL)
V2
RP3
B8
ER2
NHR
FE2
VZL

IRRAX™SLEEVE

SCM2
SBI
300/350
SNHM

Composite articles

SUMISEAL
SUMITUBE SA3 CAP

Processing equipment

SUMISHRINKER / HEATING GUN